

DESIGNED AND BUILT IN THE U.S.A.
HAWG WIRED

DCS 1202 AMPLIFIER SYSTEMS

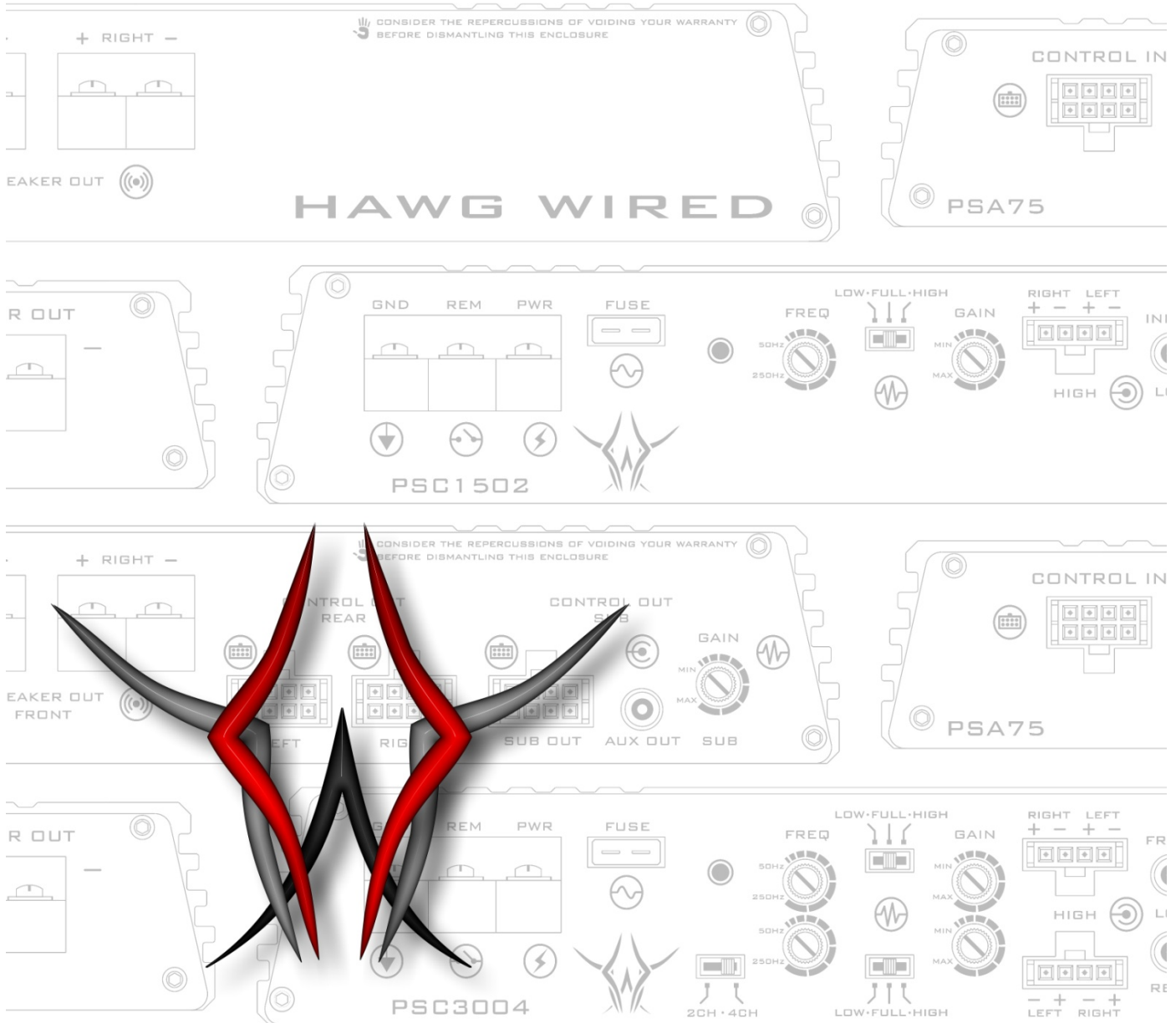

INSTALLATION GUIDE

INTRODUCTION

CONGRATULATIONS! YOU'VE JUST PURCHASED WHAT WE CONSIDER TO BE THE FINEST MOTORCYCLE AUDIO EQUIPMENT AVAILABLE. WE TAKE PRIDE IN THE FACT THAT YOU'VE CHOSEN HAWG WIRED PRODUCTS, AND WELCOME YOU TO OUR FAMILY OF AUDIOPHILE ENTHUSIASTS. OUR GOAL HERE IS SIMPLE – TO BRING HIGH PERFORMANCE AUDIO FIDELITY TO YOU, THE RIDER, WITHOUT COMPROMISING YOUR BIKE'S ELECTRICAL SYSTEM OR STORAGE SPACE. SOME SIDE EFFECTS MAY OCCUR HOWEVER, INCLUDING BUT NOT LIMITED TO; PUZZLED LOOKS FROM OTHER MOTORISTS, OCCASIONAL SHOUTS FROM YOUR NEIGHBORS, AND THE ENVY OF YOUR FRIENDS. AFTER YEARS OF DESIGN AND ENGINEERING, CUSTOM CRAFTSMANSHIP, AND A GRAVE FOR CLEAN, CLEAR, LOUD MUSIC, WE BELIEVE WE'VE NAILED THIS STUFF DOWN RIGHT.



THANK YOU FOR YOUR SUPPORT
THE HAWG WIRED TEAM

SERIAL NUMBER

PLEASE RECORD THE MODEL AND SERIAL NUMBER(S) OF YOUR EQUIPMENT IN THE SPACE PROVIDED BELOW AS YOUR PERMANENT RECORD. THESE NUMBERS CAN BE FOUND ON THE FRONT AND/OR BOTTOM OF EACH COMPONENT. THIS WILL ASSIST US WITH YOUR FACTORY WARRANTY COVERAGE, AND MAY BE USEFUL TO YOU IN THE UNFORTUNATE EVENT THAT IT'S STOLEN.

MODEL NUMBER(S):	SERIAL NUMBER(S):
_____	_____
_____	_____
_____	_____
_____	_____

KEY DESIGN FEATURES

DCS SERIES AMPLIFIER SYSTEMS INCORPORATE THE FOLLOWING KEY DESIGN FEATURES:

- CLASS-T® DIGITAL DESIGN MAKES FOR EFFICIENT POWER USAGE AND LOW HEAT DISSIPATION
- CREATES CLEAN, RAW POWER WITHOUT TAXING THE BATTERY OR CHARGING SYSTEM
- INDUSTRY STANDARD INTERFACES MAKE FOR ACROSS-THE-BOARD COMPATIBILITY
- BUILT-IN CROSSOVER CIRCUITRY FOR OPTIMAL LOUDSPEAKER PERFORMANCE
- COMPACT DESIGN ALLOWS FOR INSTALLATION AND MOUNTING IN TIGHT SPACES
- CONFORMAL COATED WEATHERPROOF PRINTED CIRCUIT BOARDS IN EVERY COMPONENT
- DIRECT CONNECT HARNESS MAKES FOR A PROFESSIONAL, CLEAN, AND EASY INSTALLATION

THIS AMPLIFIER HAS BEEN DESIGNED TO FIT INSIDE BOTH THE BATWING AND SHARKNOSE HARLEY-DAVIDSON® FAIRINGS. THE WIRING HARNESS INCLUDED HAS BEEN DESIGNED SPECIFICALLY FOR YOUR YEAR AND MODEL OF MOTORCYCLE. BE SURE THAT YOU HAVE THE CORRECT HARNESS FOR YOUR SPECIFIC APPLICATION.

THE UNIVERSAL NATURE OF THIS AMPLIFIER'S DIRECT CONNECT INTERFACE ALLOWS US TO OFFER DIFFERENT HARNESSES FOR DIFFERENT APPLICATIONS. LET US KNOW IF YOU HAVE A SPECIFIC OR CUSTOM APPLICATION THAT THIS KIT DOES NOT COVER, AND WE'LL DO WHAT WE CAN TO ACCOMMODATE YOUR NEEDS.

DID WE MENTION THAT THESE AMPLIFIERS REPRODUCE REALLY CLEAN, REALLY LOUD MUSIC?

KIT CONTENTS

KIT ITEMS INCLUDED (BY QUANTITY):	DCS1202
DCS1202 2 CHANNEL MAIN AMPLIFIER	1
18" DIRECT CONNECT WIRING HARNESS	1
LOW LEVEL (RCA TO PHONO) INPUT CABLE	1
LARGE VELCRO PAD	1
8" BLACK ZIP TIE	6
DIELECTRIC GREASE PACKET	1
ALCOHOL CLEANING PAD	2

TABLE OF CONTENTS

BEFORE YOU BEGIN 4

INSTALLATION INSTRUCTIONS..... 5

INITIAL TEAR-DOWN 5

COMPONENT MOUNTING 5

WIRING THE MAIN AMPLIFIER..... 6

REPLACING THE SPEAKERS 6

TESTING AND TUNING THE SYSTEM 7

WRAPPING IT UP..... 7

USER GUIDE..... 8

CONNECTORS AND CONTROLS 8

CONNECTORS DEFINED..... 8

SYSTEM DIAGRAMS 9

SPECIFICATIONS..... 11

BEFORE YOU BEGIN





THIS SECTION IS INTENDED TO BRING YOU UP TO SPEED WITH OUR DOCUMENTATION CONVENTIONS. WE RECOMMEND READING THIS MANUAL THOROUGHLY BEFORE BEGINNING YOUR INSTALLATION TO ACHIEVE A TROUBLE FREE, LONG LASTING OUTCOME.

TERMINOLOGY USED IN THIS MANUAL:

SOURCE UNIT	REFERS TO THE DEVICE THAT SUPPLIES THE AMPLIFIER WITH AUDIO INPUT, TYPICALLY YOUR RADIO, HEAD UNIT, MEDIA DEVICE, ETC.
MAIN AMPLIFIER	DCS1202, MASTER 2 CHANNEL AMPLIFIER THAT FUNCTIONS STANDALONE. THE BIG (LITTLE) RED BOX IN THE KIT.
DIRECT CONNECT HARNESS	USED TO CONNECT THE AMPLIFIER TO YOUR AUDIO SYSTEM. DESIGNED SPECIFICALLY FOR YEAR, MAKE, AND MODEL COMPATIBILITY.
LOW LEVEL INPUT CABLE	USED WHEN RCA CONNECTORS ARE THE SOURCE OF INPUT TO THE AMPLIFIER, TYPICALLY USED WITH AFTERMARKET SOURCE UNITS (PREFERRED METHOD).
BATWING FAIRING	HARLEY-DAVIDSON® TERM FOR THE FAIRINGS ON ELECTRA GLIDE MODELS, FORK MOUNTED, SINGLE HEADLIGHT STYLE.
SHARKNOSE FAIRING	HARLEY-DAVIDSON® TERM FOR THE FAIRINGS ON ROAD GLIDE MODELS, FRAME MOUNTED (FIXED), DUAL HEADLIGHT STYLE.
MANUFACTURER INSTRUCTIONS	REFERS TO ANY DOCUMENTATION PROVIDED BY A MANUFACTURER OTHER THAN HAWG WIRED (IE. HARLEY-DAVIDSON® SHOP REPAIR MANUAL, AFTERMARKET SOURCE UNIT OR SPEAKER MANUAL, ETC.).

QUICK CONNECT SYMBOLS:

KEEP AN EYE OUT FOR THE “QUICK CONNECT” SYMBOLS THROUGHOUT THIS MANUAL; THEY PROVIDE A VISUAL LINK BETWEEN INSTRUCTIONS, DIAGRAMS, AND THE SYSTEM COMPONENTS.

FUSE		ESSENTIAL PROTECTION FROM SHORTS
HARNESS		DIRECT CONNECT HARNESS CONNECTIONS
LINE-IN		SOURCE INPUT, LOW LEVEL OR HIGH LEVEL INPUT
POWER		POWER INDICATOR, RED LED ON FACEPLATE

NOTE: IF ANYTHING ABOUT THE INSTRUCTION OR INFORMATION PROVIDED IN THIS MANUAL IS UNCLEAR, QUESTIONABLE, OR YOU THINK WE'RE DEAD WRONG ABOUT SOMETHING, PLEASE CONTACT US.

INSTALLATION INSTRUCTIONS

INITIAL TEAR-DOWN & COMPONENT MOUNTING



USING VELCRO® AS A MOUNTING METHOD HAS THE FOLLOWING ADVANTAGES; IT HOLDS WELL UNDER EXTREME VIBRATION CONDITIONS, PROVIDES A MEASURE OF SHOCK ABSORPTION, AND ALLOWS FOR SIMPLE INSTALLATION, REMOVAL, AND ADJUSTMENT. HOWEVER, ONCE YOU STICK THOSE TWO SIDES TOGETHER WITH SOME PRESSURE, YOU'D DO WELL TO USE A PUTTY KNIFE SEPARATING THE TWO AGAIN. USING A PIECE OF PAPER OR THIN CARDBOARD BETWEEN THE 2 PIECES OF VELCRO WHEN TEST FITTING CAN MAKE THINGS A LOT EASIER.

NOTE: BE SURE TO CLEAN ALL ADHESIVE MATING SURFACES WITH THE INCLUDED ALCOHOL PADS BEFORE ATTACHING THE ADHESIVE VELCRO® PATCHES. ONCE THE ADHESIVE SIDE IS APPLIED TO A CLEAN SURFACE, WORK OUT THE AIR POCKETS WITH YOUR FINGER TIPS FOR MAXIMUM HOLDING STRENGTH AND LONGEVITY.

1. WITH THE IGNITION SWITCH OFF, CAREFULLY REMOVE THE FRONT FAIRING COVER, NOTING WHICH HOLE EACH SCREW COMES FROM, AS LENGTHS AND SIZES MAY DIFFER.

TIP: REFER TO MANUFACTURER INSTRUCTIONS IF NECESSARY, AND DON'T FORGET TO COVER YOUR FENDER.

2. DETERMINE THE MOUNTING LOCATION FOR THE AMPLIFIER BASED ON YOUR FAIRING:

2.1. BATWING FAIRINGS

MOUNT THE **AMPLIFIER** ON TOP OF THE SOURCE UNIT USING ONE OF THESE METHODS:

2005 AND OLDER - USE THE LARGE VELCRO® PATCH PROVIDED.

2006 AND NEWER - CUT THE LARGE VELCRO® PATCH IN HALF AND CHOOSE THE APPROPRIATE METHOD BELOW:

WITH BOTH FACTORY XM AND CB MODULES INSTALLED ABOVE THE SOURCE UNIT, USE THE TWO PATCH HALVES, ONE ON EACH MODULE.

WITH NO FACTORY MODULES INSTALLED ABOVE THE SOURCE UNIT, USE THE TWO PATCH HALVES, ONE ON EACH SIDE OF THE RIB RUNNING DOWN THE MIDDLE OF THE SOURCE UNIT.

WITH ONLY ONE FACTORY MODULE INSTALLED ABOVE THE SOURCE UNIT, INSTALL THE **HKA150** ADAPTER BRACKET (SOLD SEPARATELY) IN THE BLANK MODULE SLOT, AND THEN USE THE TWO PATCH HALVES, ONE ON EACH MODULE.

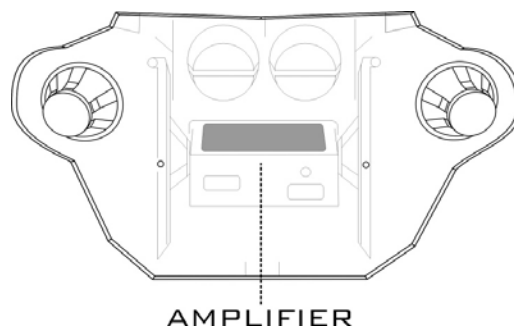

AMPLIFIER

2.2. SHARKNOSE FAIRINGS

MOUNT THE **AMPLIFIER** ON THE FLAT SPACE BEHIND THE GLOVE BOX USING THE LARGE VELCRO® PATCH PROVIDED.

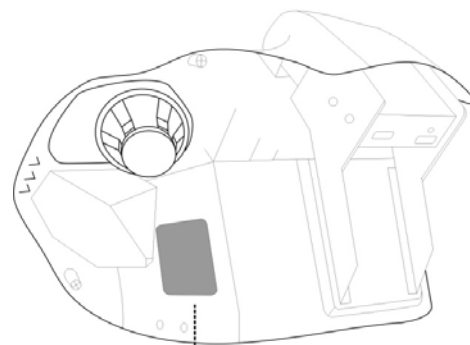

AMPLIFIER

- 2.3. CUSTOM INSTALLS - MOUNTING LOCATIONS CAN VARY, AND MUST BE TEST FIT ON A ONE-BY-ONE BASIS. THE WIRING HARNESS MAY REQUIRE CUTTING/SPLICING FOR INSTALLATIONS NOT UTILIZING A STOCK AUDIO HARNESS.



FOR ALL "TOP OF THE SOURCE UNIT" INSTALLATIONS, ENSURE THAT THE MAIN AMPLIFIER IS POSITIONED AS FAR BACK TOWARDS THE INNER FAIRING AS POSSIBLE, LEAVING JUST ENOUGH ROOM FOR THE SPEAKER WIRING AS NEEDED.

INSTALLATION INSTRUCTIONS [CONTINUED]

WIRING THE MAIN AMPLIFIER

3. DISCONNECT THE MAIN RADIO HARNESS FROM THE BACK OF THE RADIO.

NOTE: FOR 2004-2005 HIGH OUTPUT (CVO) RADIOS ONLY, BE SURE TO DISCONNECT THE AUXILIARY HARNESS AT THE BACK OF THE RADIO (GREY CONNECTOR)!

TIP: CUTTING A FEW WIRE TIES AND PULLING BACK LOOM CAN MAKE YOUR HARNESS EASIER TO WORK WITH.



4. ROUTE AND MAKE THE 3 CONNECTIONS OF THE DIRECT CONNECT WIRING HARNESS.

- 4.1. CONNECT THE AMPLIFIER HARNESS TO THE STOCK RADIO HARNESS
 4.2. CONNECT THE AMPLIFIER HARNESS TO THE BACK OF THE STOCK RADIO
 4.3. CONNECT THE AMPLIFIER HARNEES TO THE FRONT OF THE AMPLIFIER

NOTE: BE SURE THAT THE LOCATION OF THE HARNESS AND ITS CONNECTORS WILL NOT INTERFERE WITH THE FAIRING COVER AND HEADLIGHT, AND THEN SECURE IT WITH THE SUPPLIED ZIP TIES.



5. (AFTERMARKET SOURCE UNIT ONLY) CONNECT YOUR SOURCE UNITS OUTPUT RCA CONNECTORS TO THE AMPLIFIER LOW-LEVEL INPUT CONNECTOR.

NOTE: USE THE LOW-LEVEL RCA CABLE SUPPLIED WHEN CONNECTING TO AN AFTERMARKET SOURCE UNIT.



WARNING: NEVER CONNECT OR DISCONNECT THE DIRECT CONNECT HARNESS WHILE THE MAIN AMPLIFIER IS POWERED ON. THIS CAN DAMAGE THE AMPLIFIER, AND WILL VOID YOUR WARRANTY AS WELL!

REPLACING THE SPEAKERS



6. REPLACE THE FACTORY SPEAKERS WITH 4 OHM AFTERMARKET SPEAKERS (IF APPLICABLE). RECONNECT THE NEW SPEAKERS TO THE STOCK SPEAKER WIRES WITH POSITIVE (+) AND NEGATIVE (-) PROPERLY MATCHED.

NOTE: KEEP THE POLARITIES (+/-) OF EACH WIRE PAIR PROPERLY MATCHED TO THE SPEAKERS. IF YOU ARE INSTALLING HAWG WIRED SPEAKERS, REFER TO THE INSTALLATION INSTRUCTIONS THAT CAME WITH THEM. IF INSTALLING ANOTHER BRAND OF SPEAKERS, REFER TO THOSE SPECIFIC MANUFACTURER INSTRUCTIONS IF NECESSARY.

SPEAKER TERMINAL	H-D® SPEAKER WIRE COLORS		
	1998-2005 8 OHM	1998-20XX CVO ¹	2006-20XX 2 OHM
FRONT LEFT +	WHT/ORG	WHT/ORG	WHT/ORG
FRONT LEFT -	L.GRN/WHT	L.GRN/WHT	L.GRN/WHT
FRONT RIGHT +	GRY/RED	GRY/RED	GRY/RED
FRONT RIGHT -	L.GRN/BLK	L.GRN/BLK	L.GRN/BLK

NOTE¹: CVO BIKES MAY BE EQUIPPED WITH A HIGH-OUTPUT SOURCE UNIT; **DO NOT USE THE FOLLOWING WIRE COLORS: WHT/PNK, PNK, WHT/GRY, GRY.** THESE OUTPUTS CAN DAMAGE THE AMPLIFIERS INPUTS.

INSTALLATION INSTRUCTIONS [CONTINUED]

TESTING AND TUNING THE SYSTEM

7. PERFORM A BASIC SYSTEM TEST. TURN THE KEY TO THE ACCESSORY POSITION AND VERIFY THAT THE AMPLIFIER POWERS UP (LED SHOULD LIGHT) AND THAT THE SPEAKERS FUNCTION PROPERLY. IF NOT, PROCEED DIRECTLY TO “TROUBLESHOOTING” IN THE **USER GUIDE** SECTION.

WRAPPING IT UP

8. WITH THE IGNITION OFF, CAREFULLY INSTALL THE FAIRING COVER, ENSURING THAT EACH ATTACHING SCREW GOES BACK INTO THE HOLE IT CAME OUT OF. ONCE YOU HAVE EVERYTHING LINED UP AND ALL SCREWS LOOSELY INSTALLED, TIGHTEN EACH SCREW IN AN EVEN PATTERN TO AVOID BINDING.

WARNING: AVOID OVER-TIGHTENING; PLASTIC THREADS HAVE A TENDENCY TO PULL OUT EASILY. REFER TO MANUFACTURER INSTRUCTIONS IF NECESSARY.

9. PERFORM A FINAL SYSTEM TEST. TURN THE KEY TO THE ACCESSORY POSITION AND VERIFY THAT ALL COMPONENTS FUNCTION PROPERLY.

10. PERFORM A TEST RIDE AND AGAIN VERIFY THAT THE SYSTEM IS OK, AND THAT YOUR FRIENDS ARE SUFFICIENTLY JEALOUS.

TIP: JUSTIN WOULD LIKE TO REMIND YOU TO CHECK YOUR TIRE PRESSURE, AND FROM THE ENTIRE HAWG WIRED TEAM, THANKS FOR MAKING THIS POSSIBLE, KEEP THE RUBBER SIDE DOWN, AND CRANK IT!

USER GUIDE

CONNECTORS AND CONTROLS

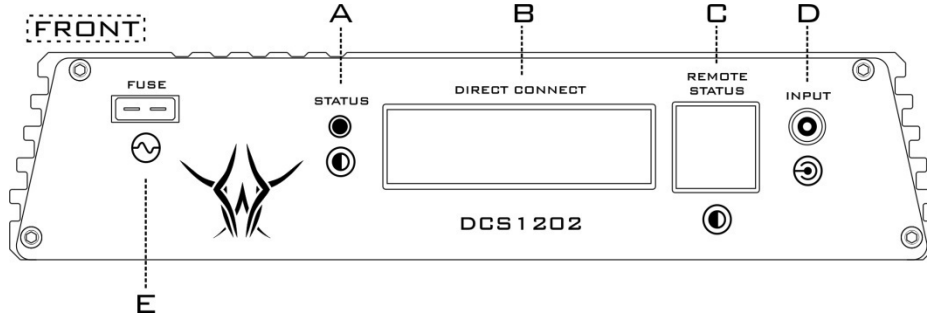

PLANNING YOUR SYSTEM CONFIGURATION IS THE FIRST STEP TOWARDS HI-FI HAPPINESS, AND IT'S TIME YOU GET FAMILIAR WITH ALL THE BELLS AND WHISTLES ON YOUR NEW AMPLIFIER. THE TABLE BELOW LISTS THE CONTROLS AND CONNECTORS ON THE DCS1202 FACEPLATES.

A	POWER/STATUS INDICATOR	E	AMPLIFIER PROTECTION FUSE		
B	DIRECT CONNECT HARNESS INPUT				
C	REMOTE POWER/STATUS INDICATOR				
D	LOW LEVEL INPUT				

CONNECTORS DEFINED



LOW LEVEL INPUT CONNECTOR:

THIS CONNECTOR ALLOWS THE AMPLIFIER TO USE INDUSTRY STANDARD RCA OUTPUTS FROM AN AFTERMARKET SOURCE UNIT AS INPUTS TO THE AMPLIFIER. THIS IS THE PREFERRED METHOD WHEN RCA OUTPUTS ARE AVAILABLE.

NOTE: WE USE INDUSTRY STANDARD 3.5MM HEADPHONE STYLE JACKS ON THE AMPLIFIER DUE TO THE SPACE CONSTRAINTS. ALTHOUGH WE HIGHLY RECOMMEND USING THE LOW LEVEL INPUT CABLES WE SUPPLY WITH THE KIT, YOU SHOULD BE ABLE TO UTILIZE ANY STANDARD RCA TO PHONO ADAPTER CABLE FOUND AT YOUR LOCAL ELECTRONIC STORE TO MAKE THESE CONNECTIONS.



DIRECT CONNECT INTERFACE CONNECTOR:

THIS IS THE PIN CONFIGURATION OF THE 20 PIN AMPLIFIER CONNECTOR. THIS IS FOR REFERENCE ONLY. ADDITIONAL WIRING IS ONLY REQUIRED FOR CUSTOM APPLICATIONS.

PIN NUMBER	FUNCTION	PIN NUMBER	FUNCTION
A1	RIGHT + INPUT	B1	RIGHT - INPUT
A2	LEFT + INPUT	B2	LEFT - INPUT
A3	RIGHT + OUTPUT	B3	RIGHT - OUTPUT
A4	LEFT + OUTPUT	B4	LEFT - OUTPUT
A5		B5	
A6		B6	
A7		B7	
A8	GROUND	B8	GROUND
A9		B9	+12V REMOTE ON
A10	+12V POWER	B10	+12V POWER

NOTE: CVD BIKES MAY BE EQUIPPED WITH A HIGH-OUTPUT SOURCE UNIT; **DO NOT USE THE FOLLOWING WIRE COLORS: WHT/PNK, PNK, WHT/GRY, GRY.** THESE OUTPUTS CAN DAMAGE THE AMPLIFIERS INPUTS.

SYSTEM DIAGRAM

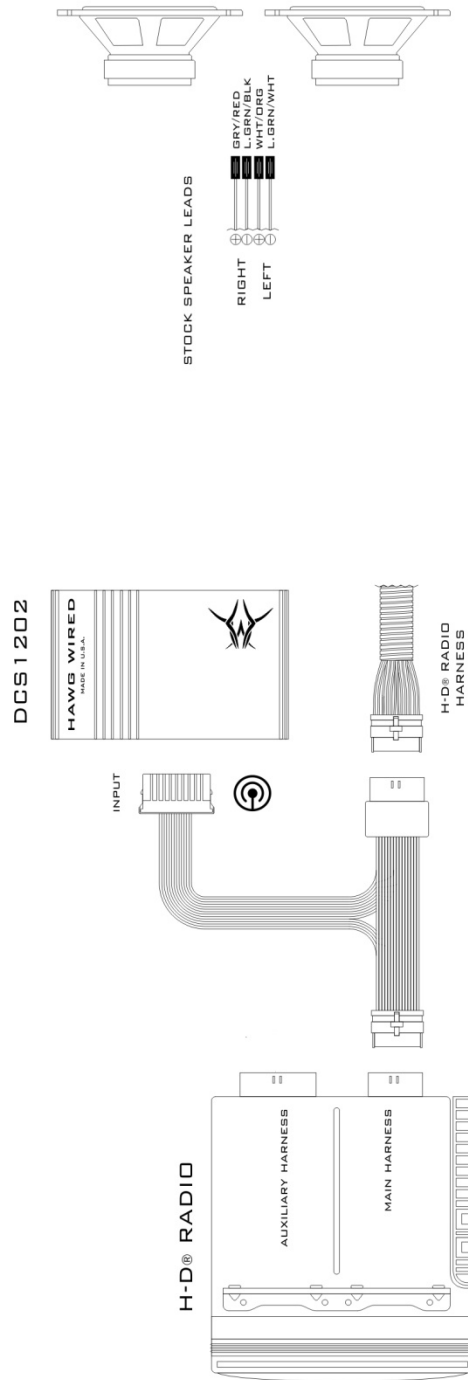

DIRECT CONNECT - DCS SERIES 2CH - H-D® RADIO

SYSTEM DIAGRAM

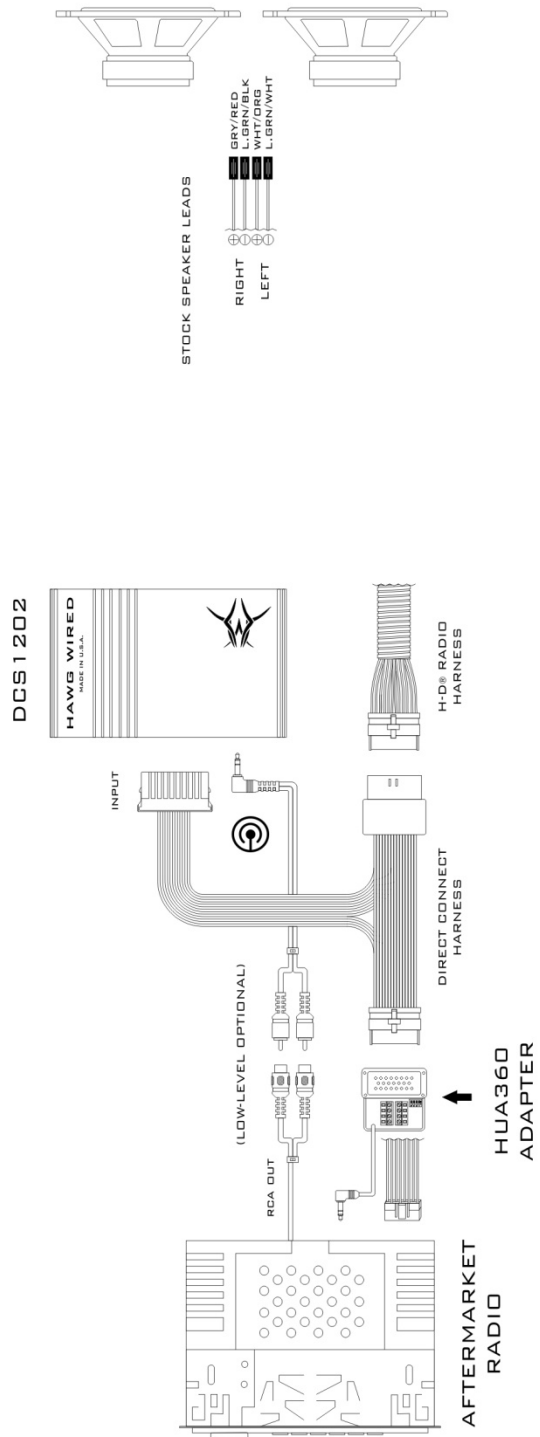

DIRECT CONNECT - DCS SERIES 2CH - HUA360

SPECIFICATIONS

DCS1202

INPUT CHANNELS: 2 HIGH AND LOW LEVEL
 OUTPUT CHANNELS: 2 CHANNELS
 NOMINAL OUTPUT IMPEDANCE: 4 OHMS
 NOMINAL POWER OUTPUT (WATTS RMS): 120 (2 X 60) WATTS
 FREQUENCY RESPONSE: 125HZ-50KHZ
 LOW LEVEL (RCA LINE-IN) SENSITIVITY: 200MV - 6V
 HIGH LEVEL (SPEAKER-IN) SENSITIVITY: 400MV - 12V
 INPUT IMPEDANCE: 33K OHMS

CASE DIMENSIONS

MAIN AMPLIFIER: 6.50" W X 3.75" D X 1.50" H

TYPICAL SOUND REPRODUCTION QUALITY: 0.010% THD+N @ 60W 4Ω

SPECIFICATIONS ARE SUBJECT TO CHANGE WITHOUT NOTICE

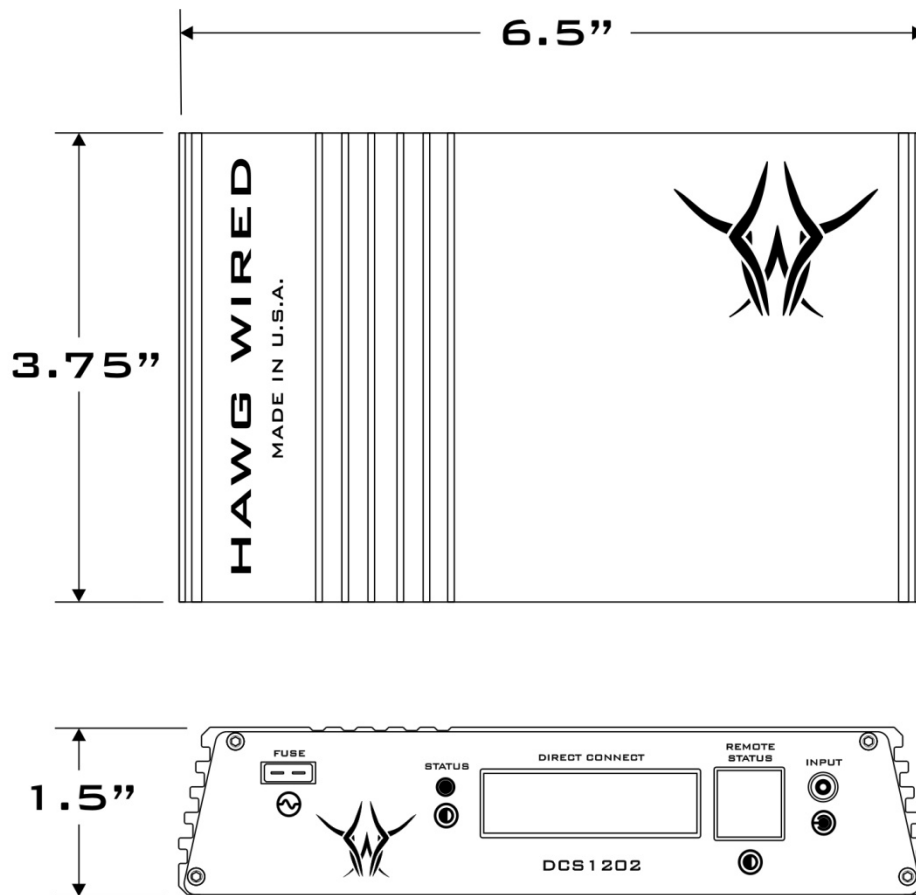

DCS1202

DIMENSIONS IN INCHES

WARRANTY INFORMATION

HAWG WIRED OFFERS A LIMITED WARRANTY OF OUR PRODUCTS ON THE FOLLOWING TERMS:

- **LENGTH OF WARRANTY**

1 YEAR ON AUDIO SYSTEMS, ELECTRONICS, SPEAKERS, AND ACCESSORIES (RECEIPT REQUIRED).

- **COVERAGE**

THIS WARRANTY COVERS ONLY THE ORIGINAL PURCHASER OF A HAWG WIRED PRODUCT PURCHASED FROM AN AUTHORIZED HAWG WIRED DEALER IN THE UNITED STATES. IN ORDER TO RECEIVE SERVICE, THE PURCHASER MUST PROVIDE HAWG WIRED WITH A COPY OF THE RECEIPT STATING THE CUSTOMER NAME, DEALER NAME, PRODUCT PURCHASED AND DATE OF PURCHASE.

- **DEFECTIVE PRODUCTS**

PRODUCTS FOUND TO BE DEFECTIVE DURING THE WARRANTY PERIOD WILL BE REPAIRED OR REPLACED (WITH A PRODUCT DEEMED TO BE EQUIVALENT) AT HAWG WIRED'S DISCRETION.

- **WHAT IS NOT COVERED**

DAMAGE CAUSED BY ACCIDENT, ABUSE, IMPROPER OPERATIONS, WATER, THEFT
 ANY COST OR EXPENSE RELATED TO THE REMOVAL OR REINSTALLATION OF PRODUCT
 SERVICE PERFORMED BY ANYONE OTHER THAN AN AUTHORIZED HAWG WIRED SERVICE CENTER
 ANY PRODUCT WITH THE SERIAL NUMBER OR TAMPER LABELS DEFACED, ALTERED, OR REMOVED
 SUBSEQUENT DAMAGE TO OTHER COMPONENTS
 ANY PRODUCT PURCHASED OUTSIDE THE U.S.
 ANY PRODUCT NOT PURCHASED FROM AN AUTHORIZED HAWG WIRED DEALER

- **LIMIT ON IMPLIED WARRANTIES**

ANY IMPLIED WARRANTIES INCLUDING WARRANTIES OF FITNESS FOR USE AND MERCHANTABILITY ARE LIMITED IN DURATION TO THE PERIOD OF THE EXPRESS WARRANTY SET FORTH ABOVE. SOME STATES DO NOT ALLOW LIMITATIONS ON THE LENGTH OF AN IMPLIED WARRANTY, SO THIS LIMITATION MAY NOT APPLY. NO PERSON IS AUTHORIZED TO ASSUME FOR HAWG WIRED ANY OTHER LIABILITY IN CONNECTION WITH THE SALE OF THE PRODUCT.

- **HOW TO OBTAIN SERVICE**

PLEASE CALL 510.894.2999 FOR HAWG WIRED CUSTOMER SERVICE. YOU MUST OBTAIN A RETURN MATERIAL AUTHORIZATION NUMBER (RMA) TO RETURN ANY PRODUCT TO HAWG WIRED. YOU ARE RESPONSIBLE FOR SHIPPING CHARGES OF RETURNED PRODUCTS TO HAWG WIRED.

- **MADE IN THE USA**

OUR PRODUCTS ARE PROUDLY DESIGNED, DEVELOPED AND BUILT IN THE USA*. THE MAJORITY OF THE COMPONENTS USED IN THE CONSTRUCTION OF OUR PRODUCTS ARE PRODUCED BY AMERICAN COMPANIES. HOWEVER, DUE TO THE GLOBAL NATURE OF MODERN MANUFACTURING AND THE ELECTRONICS INDUSTRY IN GENERAL, SOME PARTS MAY BE MANUFACTURED IN OTHER COUNTRIES.

*OUR SPEAKERS ARE PROUDLY DESIGNED AND DEVELOPED IN THE USA. HOWEVER, DUE TO THE GLOBAL NATURE OF LOUDSPEAKER MANUFACTURING, OUR SPEAKERS ARE MANUFACTURED IN OTHER COUNTRIES.

HAWG WIRED, INC.

CONTACT US BY EMAIL

GENERAL INFORMATION – info@hawg-wired.com
 SALES AND MARKETING – sales@hawg-wired.com
 TECHNICAL SUPPORT – tech@hawg-wired.com

CONTACT US BY PHONE

MAIN 510.894.2999
 EFAX 510.217.6994

VISIT US ON THE WEB AT HAWG-WIRED.COM



COPYRIGHT © 2009 HAWG WIRED, INC. ALL RIGHTS RESERVED.

REV.2A PRINTED IN THE U.S.A.